

cilindri ad asta gemellata

twin rod cylinders

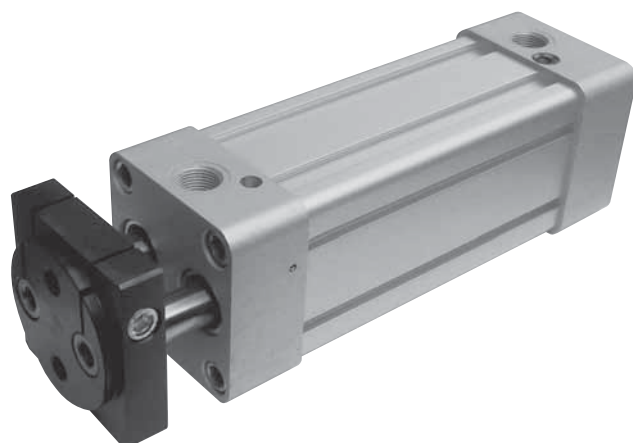

- Grande affidabilità e lunga durata
High reliability and long life time
- Versione magnetica standard
Standard magnetic version
- Ammortizzo pneumatico standard su tutta la gamma
Pneumatic cushioning standard on the whole range
- Esecuzioni e corse speciali a richiesta
Special versions and strokes on request



6 Materiali

Camicia: alluminio

Steli: C45 cromato

Testate: alluminio

Pistone: alluminio

Guarnizioni: NBR

Flangia: acciaio brunito

Boccole guida stelo: bronzo sinterizzato

Guida pistone: PTFE a basso attrito

Materials

Barrel: aluminium

Piston-rods: C45 (chromium plated)

End-cups: aluminium

Piston: aluminium

Sealings: NBR

Flange: burnished steel

Rod guides: sintered bronze

Piston guide: low friction PTFE

Pressione di esercizio <i>Working pressure</i>	max 10 bar max 1 MPa
Temperatura di esercizio <i>Temperature range</i>	max +60°C
Alesaggi <i>Bores</i>	32; 40; 50; 63; 80; 100 mm
Corse <i>Strokes</i>	25; 50; 80; 100; 125; 150; 160; 200; 250; 300; 320; 400; 500 mm
Fluido <i>Fluid</i>	Aria filtrata 50µ con o senza lubrificazione <i>50µ filtered, lubricated or non lubricated air</i>

chiave di codifica

key to codes

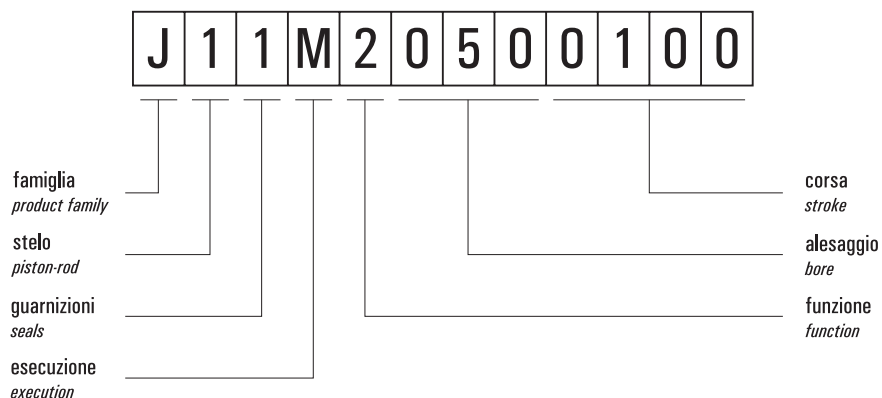

Famiglia *[product family]*

J cilindri ad asta gemellata
[twin rod cylinders]

Steli *[piston-rods]*

1 C45 cromato *[C45 chromium plated]*

Guarnizioni *[seals]*

1 NBR

Esecuzione *[execution]*

M magnetico *[magnetic]*

Funzione *[function]*

- 2** doppio effetto ammortizzato
[double acting with pneumatic cushioning]
- 4** doppio effetto ammortizzato stelo passante ISO
[double acting with pneumatic cushioning, with ISO passing-through rod]
- 9** doppio effetto ammortizzato asta gemellata passante
[double acting with pneumatic cushioning, with twin passing-through rod]

cilindri ad asta gemellata

twin rod cylinders

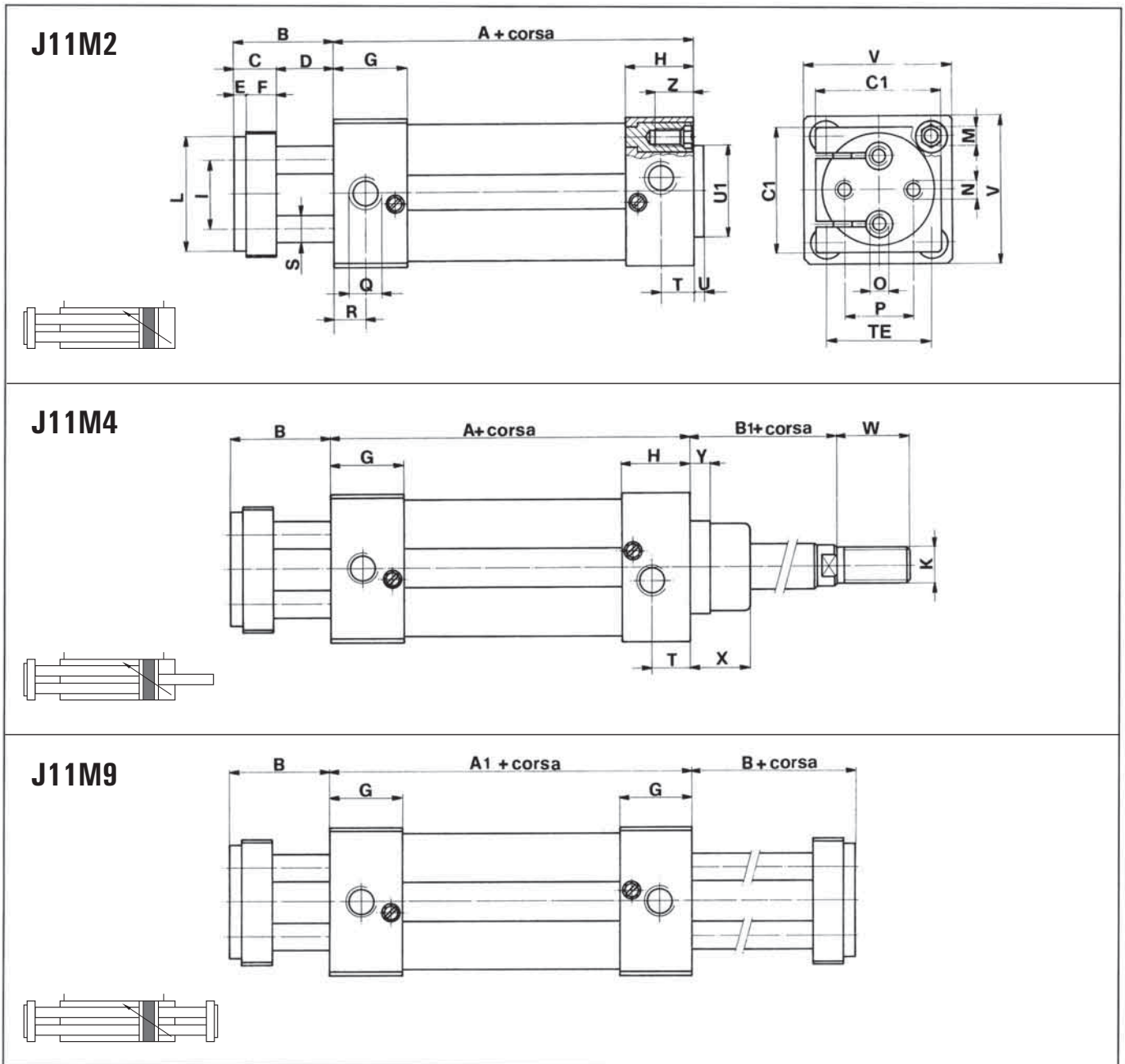

6

Ø	A	A1	B	B1	C	C1	D	E	F	G	H	I	L	M	N	O	P	Q
32	100	111	40	26	15	45	25	4	11	30	24,5	18	32	M6	M6	-	19	G1/8
40	101	104	40	30	15	50	25	4	11	26,5	27,5	22	40	M6	M8	-	22	G1/4
50	108,5	113	43	37	18	55	25	5	13	32	31	30	50	M8	M8	M8	30	G1/4
63	119	125	47	37	22	70	25	5	17	34	35,5	38	63	M8	M10	M10	38	G3/8
80	134	135	50	46	25	90	25	5	20	38	40	48	80	M10	M12	M12	50	G3/8
100	144	142	50	51	25	110	25	5	20	36	43	60	100	M10	M12	M12	70	G1/2
Ø	R	S	T	TE	U	U1	V	Z	W	Y	X	K						
32	13	10	14	32,5	4	30	45	18	22	6	20	M10X1,25						
40	11,5	10	17	38	4	35	52	18	24	6	22	M12X1,25						
50	14	12	18	46,5	4	40	65	23	32	8	26	M16X1,5						
63	14	16	17,5	56,5	4	45	75	23	32	8	26	M16X1,5						
80	15	22	20,5	72	4	45	95	30	40	10	40	M20X1,5						
100	15	22	18	89	4	55	115	30	40	10	40	M20X1,5						

cilindri ad asta gemellata

twin rod cylinders



FLANGIA

FLIS...

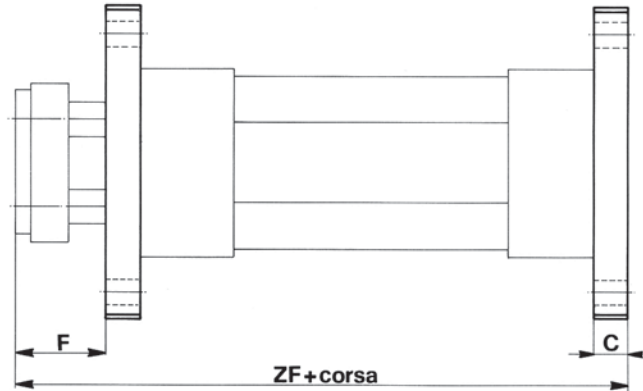
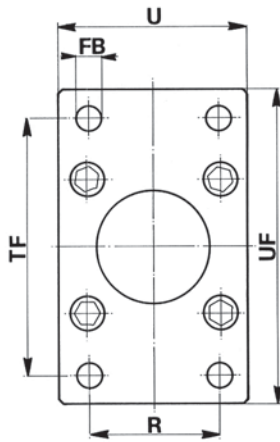

∅	DIM.	C	F	R	U	FB	TF	UF	ZF
32		10	30	32	45	7	64	80	150
40		10	30	36	52	9	72	90	151
50		12	31	45	65	9	90	110	163,5
63		12	35	50	75	9	100	120	178
80		16	34	63	95	12	126	150	200
100		16	34	75	115	14	150	170	210

La flangia ISO standard si può montare sulla testata posteriore di tutti gli alesaggi. Sulla testata anteriore si può montare solo sugli alesaggi 32 e 40. Per gli altri alesaggi contattare l'ufficio commerciale.

The standard ISO flange can be mounted on the back end-cup for all bores. On the front end-cup it can be mounted only for bore 32 and 40. For other bores please contact our commercial office.

CERNIERA MASCHIO

CMIS...

CMKS...

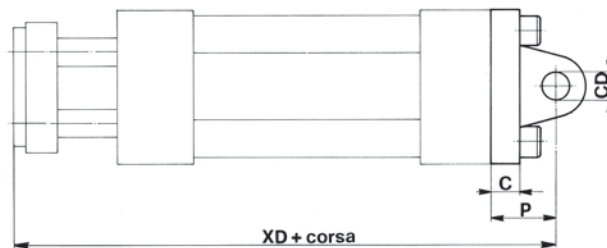
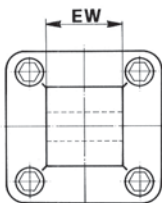

∅	DIM.	C	CD	P	EW	XD
32		9	10	22	26	162
40		9	12	25	28	166
50		11	12	27	32	178,5
63		11	16	32	40	198
80		14	16	36	50	220
100		14	20	41	60	235

cilindri ad asta gemellata

twin rod cylinders



PIEDINO

PBIS...

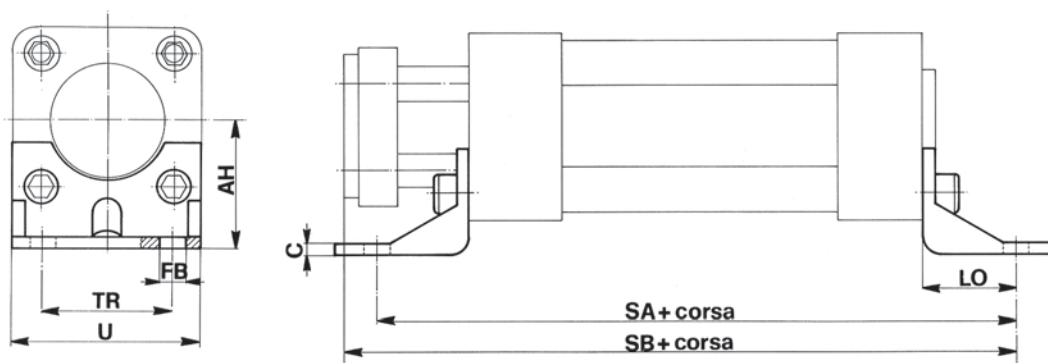

ø	DIM.	C	AH	FB	LO	SA	SB	TR	U
32		4	32	7	24	148	164	32	45
40		4	36	9	28	157	169	36	52
50		5	45	9	32	172,5	183,5	45	65
63		5	50	9	32	183	198	50	75
80		6	63	12	41	216	225	63	95
100		6	71	14	41	226	235	75	115

CERNIERA FEMMINA CON PERNO

CFIS...

CFKS...

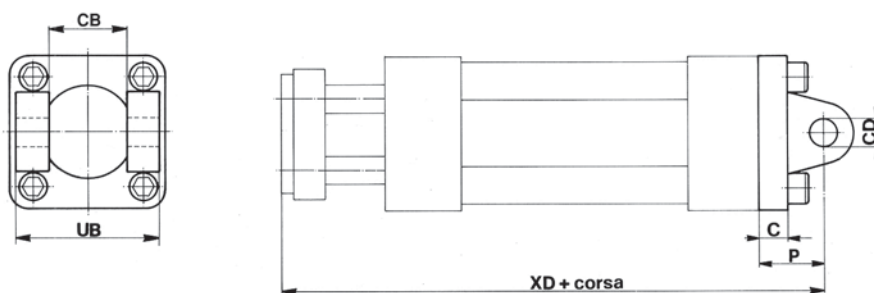

ø	DIM.	C	CD	P	CB	UB	XD
32		9	10	22	26	45	162
40		9	12	25	28	52	166
50		11	12	27	32	60	178,5
63		11	16	32	40	70	198
80		14	16	36	50	90	220
100		14	20	41	60	110	235

momenti flettenti

bending moments

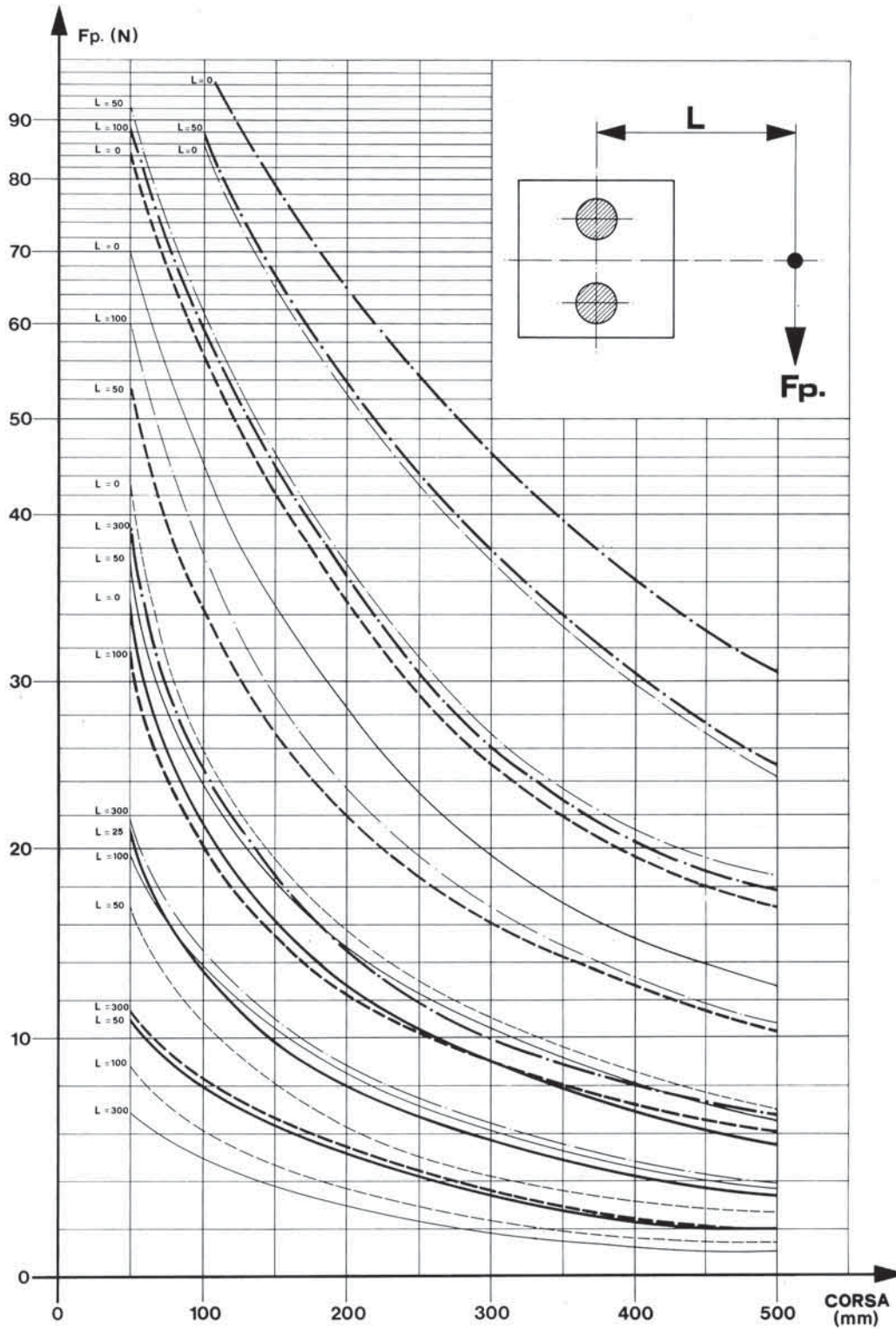

cilindri ad asta gemellata

twin rod cylinders



carichi a flessione

flexion loads

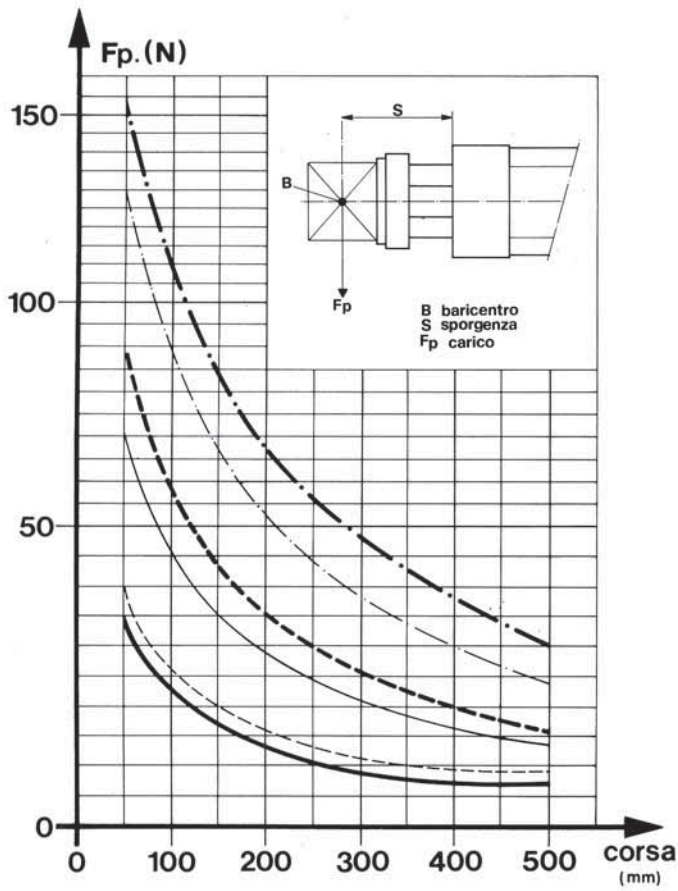

momenti torcenti

twisting moments

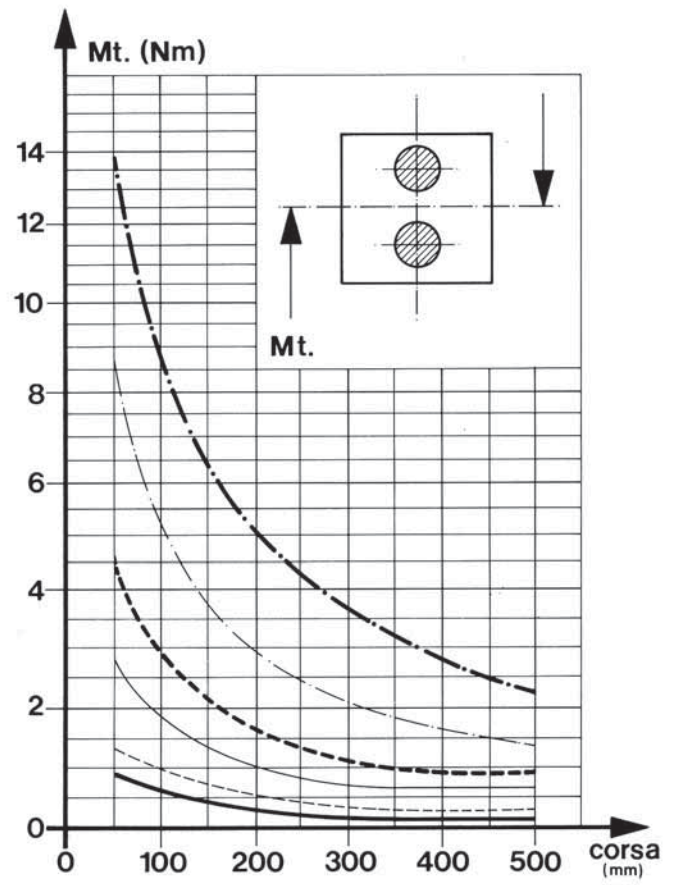

6