

# gruppo trattamento aria FR+L G1/4"

G1/4" FR+L air preparation unit



- Il gruppo comprende: filtroregolatore e lubrificatore  
*The unit includes: filter-regulator and oil mist lubricator*
- Separazione condensa: > 90%  
*Moisture separation: > 90%*
- Scarico semiautomatico della condensa; rifornimento olio manuale  
*Semi-automatic moisture exhaust; manual oil refilling*
- Capacità delle tazze: 12 cm<sup>3</sup> (condensa), 35 cm<sup>3</sup> (olio)  
*Bowl capacity: 12 cm<sup>3</sup> (moisture), 35 cm<sup>3</sup> (oil)*
- Installazione verticale; staffa di fissaggio a richiesta (cod. STF 2)  
*Vertical installation; bracket on request (code STF 2)*



CODICE DI ORDINAZIONE ORDER CODE		FR+L 2-08-25-S
Attacchi <i>Ports</i>		G1/4"
Temperatura di esercizio <i>Temperature range</i>		max +50°C
Peso <i>Weight</i>		0.32 kg
Pressione di alimentazione <i>Inlet pressure range</i>	$p_{1 \text{ min}}$ $p_{1 \text{ max}}$	0 bar; 0 MPa 10 bar; 1 MPa
Pressione di utilizzo <i>Outlet pressure range</i>	$p_{2 \text{ min}}$ $p_{2 \text{ max}}$	0.5 bar; 0.05 MPa 8 bar; 0.8 MPa
Differenza minima di pressione ( $\Delta p$ ) <i>Minimum pressure difference (<math>\Delta p</math>)</i>	$p_1 - p_2$	0.2 bar; 0.02 MPa
Isteresi <i>Hysteresis</i>	$p_1 = 10 \text{ bar} / p_2 = 0 \text{ bar}$ $p_1 = 10 \text{ bar} / p_2 = 8 \text{ bar}$	1.6 0.6
Portata raccomandata <i>Recommended flow rate</i>	$p_2 = 6.3 \text{ bar a } 25 \text{ m/s}$ $p_2 = 6.3 \text{ bar at } 25 \text{ m/s}$	$Q_n$
Elemento filtrante <i>Filter element</i>		550 NI/min (max 580 NI/min)
		25 $\mu\text{m}$

Caratteristiche di portata  
*Flow characteristics*

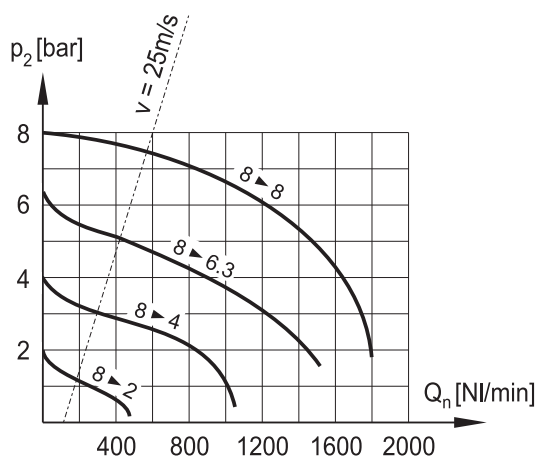

# gruppo trattamento aria FR+L G1/4"

G1/4" FR+L air preparation unit



La staffa di fissaggio e il manometro devono essere acquistati separatamente.  
Mounting bracket and manometer are bought separately.

Protezione in plastica della tazza a richiesta (cod. PR 2-00)  
Plastic bowl protection on request (code PR 2-00)

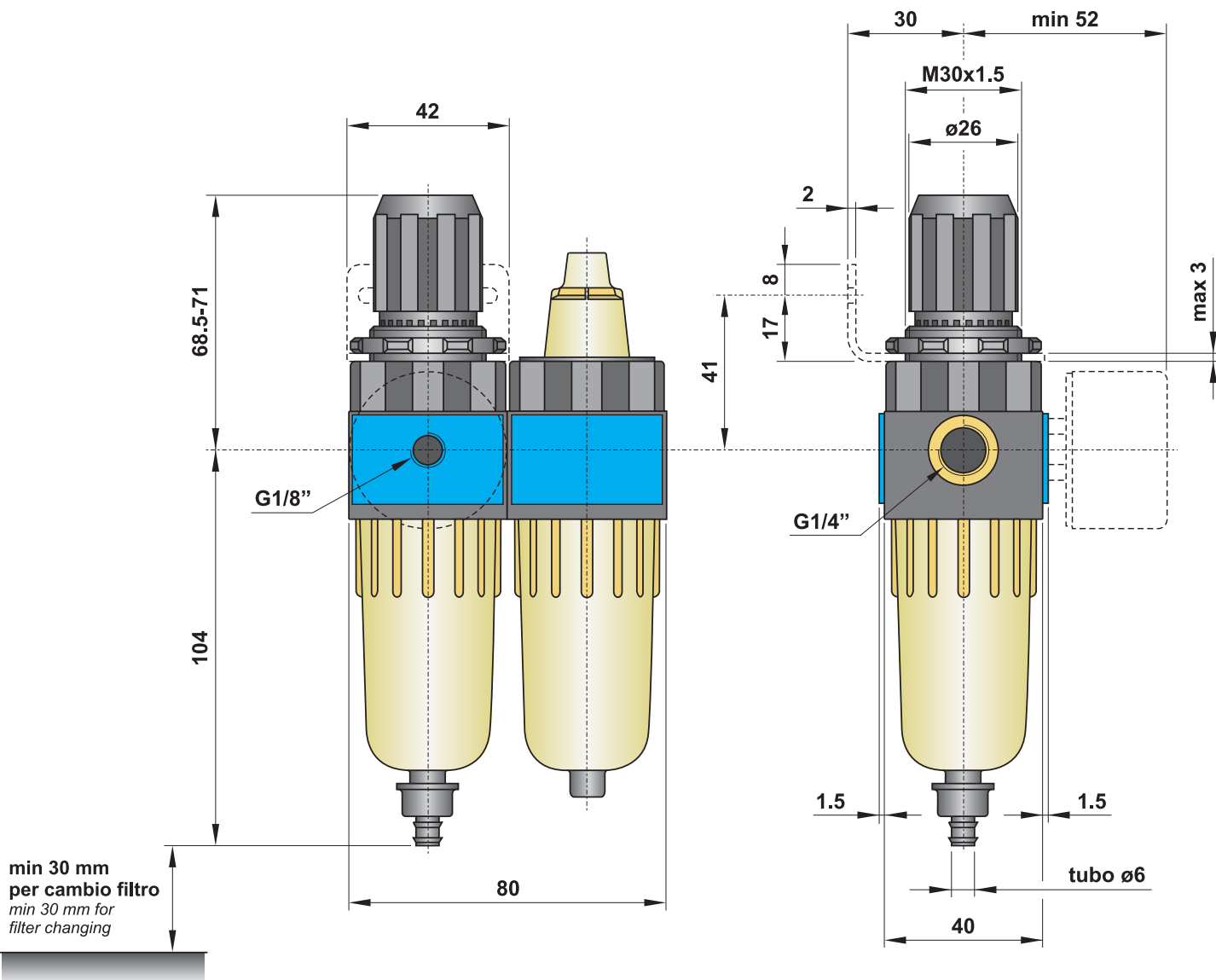
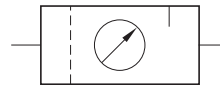

## Materiali

Corpo: polimero rinforzato con inserti filettati in ottone

Molle: INOX

Guarnizioni: NBR

Parti interne: ottone, INOX e polimeri

Tazze: policarbonato rinforzato

## Materials

Body: reinforced polymer with brass thread inserts

Springs: stainless steel

Seals: NBR

Internal parts: brass, stainless steel and polymer

Bowls: reinforced polycarbonate

# gruppo trattamento aria FR+L G3/8"

G3/8" FR+L air preparation unit



- Il gruppo comprende: filtroregolatore e lubrificatore  
*The unit includes: filter-regulator and oil mist lubricator*
- Separazione condensa: > 90%  
*Moisture separation: > 90%*
- Scarico semiautomatico della condensa; rifornimento olio manuale  
*Semi-automatic moisture exhaust; manual oil refilling*
- Capacità delle tazze: 22 cm<sup>3</sup> (condensa), 45 cm<sup>3</sup> (olio)  
*Bowl capacity: 22 cm<sup>3</sup> (moisture), 45 cm<sup>3</sup> (oil)*
- Installazione verticale; staffa di fissaggio a richiesta (cod. STF 3 o STF 3A)  
*Vertical installation; bracket on request (code STF 3 or STF 3A)*
- Protezione metallica della tazza a richiesta (cod. PR 3-00)  
*Metal bowl protection on request (code PR 3-00)*



CODICE DI ORDINAZIONE <i>ORDER CODE</i>		FR+L 3-08-30-S
Attacchi <i>Ports</i>		G3/8"
Temperatura di esercizio <i>Temperature range</i>		max +50°C
Peso <i>Weight</i>		0.75 kg
Pressione di alimentazione <i>Inlet pressure range</i>	$p_{1 \min}$ $p_{1 \max}$	0 bar; 0 MPa 16 bar; 1.6 MPa
Pressione di utilizzo <i>Outlet pressure range</i>	$p_{2 \min}$ $p_{2 \max}$	0.5 bar; 0.05 MPa 8 bar; 0.8 MPa
Differenza minima di pressione ( $\Delta p$ ) <i>Minimum pressure difference (<math>\Delta p</math>)</i>	$p_1 - p_2$	0.2 bar; 0.02 MPa
Isteresi <i>Hysteresis</i>	$p_1 = 10 \text{ bar} / p_2 = 0 \text{ bar}$ $p_1 = 10 \text{ bar} / p_2 = 8 \text{ bar}$	0.5 0.4
Portata raccomandata <i>Recommended flow rate</i>	$p_2 = 6 \text{ bar a } 25 \text{ m/s}$ $p_2 = 6 \text{ bar at } 25 \text{ m/s}$	$Q_n$ 680 NI/min
Elemento filtrante <i>Filter element</i>		30 $\mu\text{m}$

Caratteristiche di portata  
*Flow characteristics*

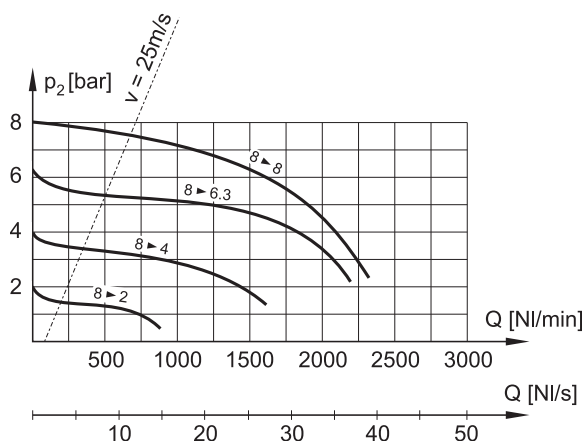

# gruppo trattamento aria FR+L G3/8"

G3/8" FR+L air preparation unit



La staffa di fissaggio, la ghiera e il manometro devono essere acquistati separatamente.  
Mounting bracket, ring and manometer are bought separately.

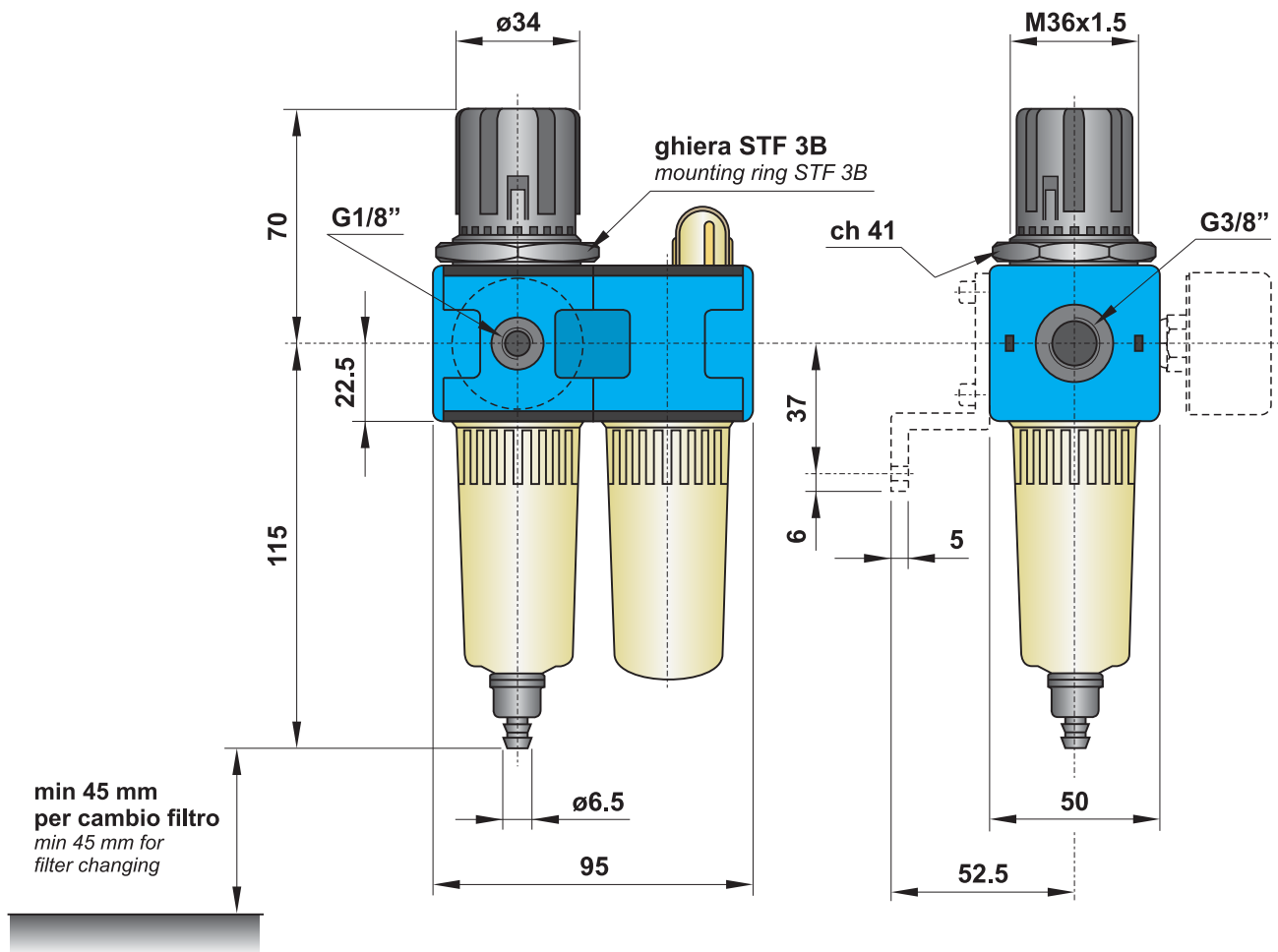
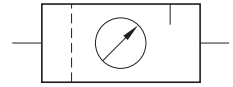

## Materiali

Corpo: alluminio pressofuso

Guarnizioni: NBR

Parti interne: ottone e INOX

Parti esterne: polimeri rinforzati

Tazze: policarbonato rinforzato

## Materials

Body: die-cast aluminium

Seals: NBR

Internal parts: brass and stainless steel

External parts: reinforced polymer

Bowls: reinforced polycarbonate

# gruppo trattamento aria FR+L G1/2"

G1/2" FR+L air preparation unit



- Il gruppo comprende: filtroregolatore e lubrificatore  
*The unit includes: filter-regulator and oil mist lubricator*
- Separazione condensa: 95%  
*Moisture separation: 95%*
- Scarico semiautomatico della condensa; rifornimento olio manuale  
*Semi-automatic moisture exhaust; manual oil refilling*
- Capacità delle tazze: 57 cm<sup>3</sup> (condensa), 112 cm<sup>3</sup> (olio)  
*Bowl capacity: 57 cm<sup>3</sup> (moisture), 112 cm<sup>3</sup> (oil)*
- Installazione verticale; staffa di fissaggio a richiesta (cod. STF 4)  
*Vertical installation; bracket on request (code STF 4)*
- Protezione metallica della tazza a richiesta (cod. PR 4-00)  
*Metal bowl protection on request (code PR 4-00)*



CODICE DI ORDINAZIONE <i>ORDER CODE</i>		FR+L 4-08-30-S
Attacchi <i>Ports</i>		G1/2"
Temperatura di esercizio <i>Temperature range</i>		max +50°C
Peso <i>Weight</i>		1.5 kg
Pressione di alimentazione <i>Inlet pressure range</i>	$p_{1 \text{ min}}$ $p_{1 \text{ max}}$	0 bar; 0 MPa 16 bar; 1.6 MPa
Pressione di utilizzo <i>Outlet pressure range</i>	$p_{2 \text{ min}}$ $p_{2 \text{ max}}$	0.5 bar; 0.05 MPa 8 bar; 0.8 MPa
Differenza minima di pressione ( $\Delta p$ ) <i>Minimum pressure difference (<math>\Delta p</math>)</i>	$p_1 - p_2$	0.2 bar; 0.02 MPa
Isteresi <i>Hysteresis</i>	$p_1 = 10 \text{ bar} / p_2 = 0 \text{ bar}$ $p_1 = 10 \text{ bar} / p_2 = 8 \text{ bar}$	0.9 0.7
Portata raccomandata <i>Recommended flow rate</i>	$p_2 = 6 \text{ bar a } 25 \text{ m/s}$ $p_2 = 6 \text{ bar at } 25 \text{ m/s}$	$Q_n$ 1900 NI/min
Elemento filtrante <i>Filter element</i>		30 $\mu\text{m}$

Caratteristiche di portata  
*Flow characteristics*

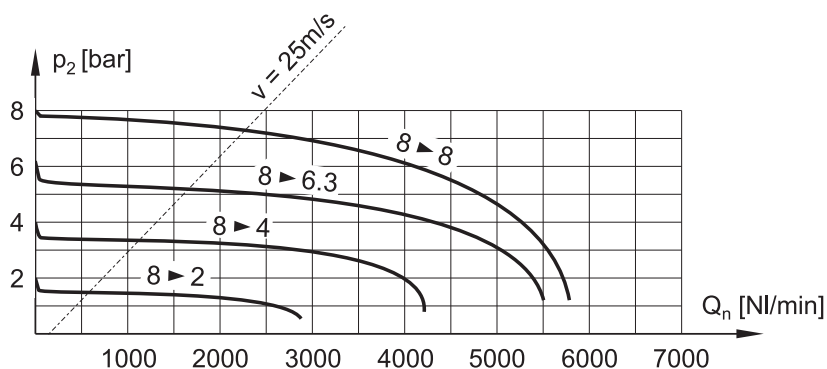

# gruppo trattamento aria FR+L G1/2"

G1/2" FR+L air preparation unit



La staffa di fissaggio e il manometro devono essere acquistati separatamente.  
Mounting bracket and manometer are bought separately.

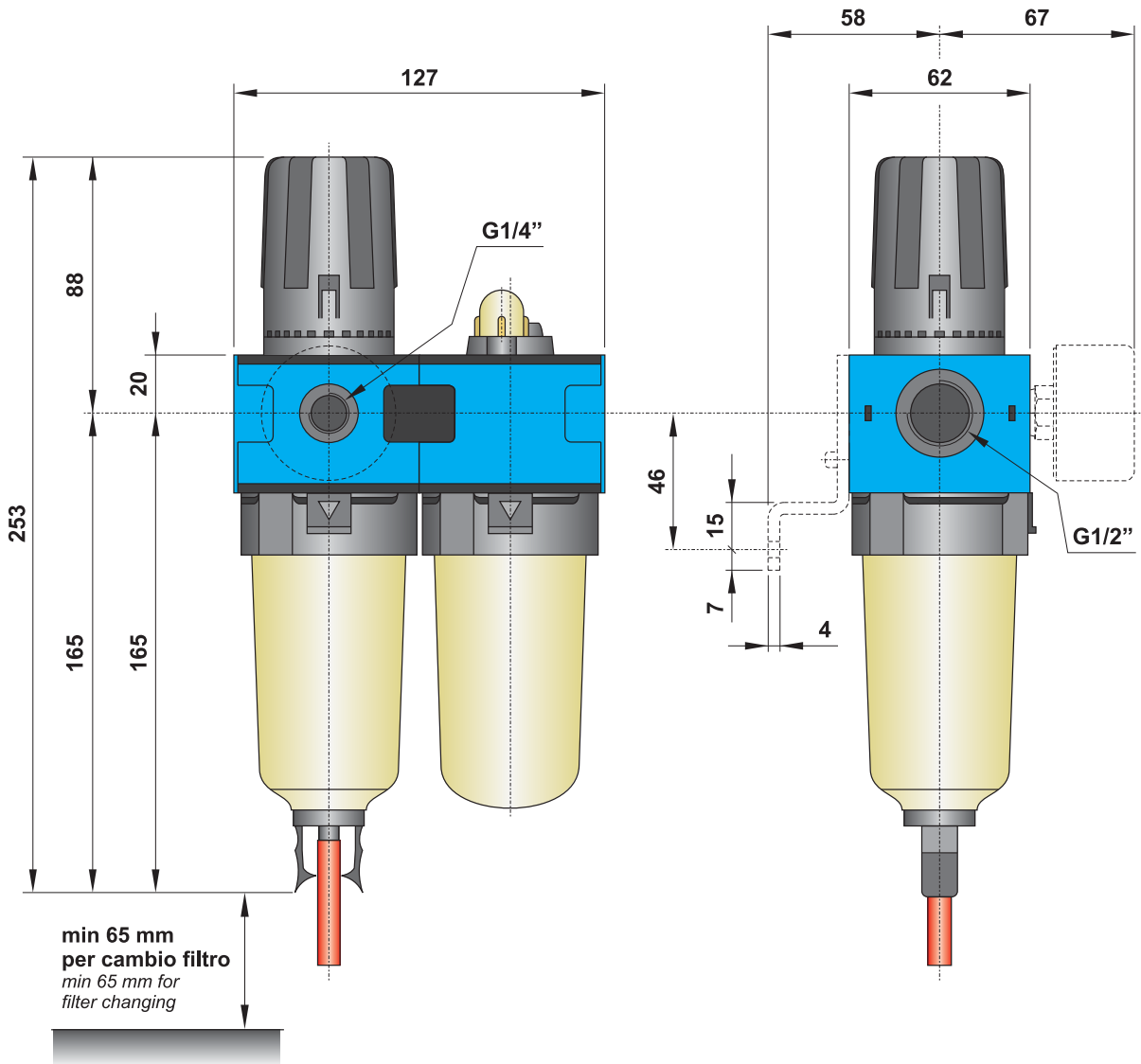
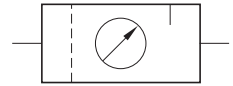

## Materiali

Corpo: alluminio pressofuso

Guarnizioni: NBR

Parti interne: ottone e INOX

Parti esterne: polimeri rinforzati

Tazze: policarbonato rinforzato

## Materials

Body: die-cast aluminium

Seals: NBR

Internal parts: brass and stainless steel

External parts: reinforced polymer

Bowls: reinforced polycarbonate

# gruppo trattamento aria FR+L G1"

G1" FR+L air preparation unit



- Il gruppo comprende: filtroregolatore e lubrificatore  
*The unit includes: filter-regulator and oil mist lubricator*
- Separazione condensa: 96%  
*Moisture separation: 96%*
- Scarico semiautomatico della condensa; rifornimento olio manuale  
*Semi-automatic moisture exhaust; manual oil refilling*
- Capacità delle tazze: 130 cm<sup>3</sup> (condensa), 500 cm<sup>3</sup> (olio)  
*Bowl capacity: 130 cm<sup>3</sup> (moisture), 500 cm<sup>3</sup> (oil)*
- Installazione verticale; staffe di fissaggio a richiesta (cod. STF 6N; STF 6NA; STF 6NB)  
*Vertical installation; brackets on request (code STF 6N; STF 6NA; STF 6NB)*
- Tazza metallica  
*Metal bowl*



CODICE DI ORDINAZIONE ORDER CODE		FR+L 6N-10-30-S
Attacchi <i>Ports</i>		G1"
Temperatura di esercizio <i>Temperature range</i>		max +50°C
Peso <i>Weight</i>		2.8 kg
Pressione di alimentazione <i>Inlet pressure range</i>	$p_{1 \text{ min}}$ $p_{1 \text{ max}}$	0 bar; 0 MPa 17.5 bar; 1.75 MPa
Pressione di utilizzo <i>Outlet pressure range</i>	$p_{2 \text{ min}}$ $p_{2 \text{ max}}$	0.5 bar; 0.05 MPa 12 bar; 1.2 MPa
Portata massima <i>Maximum flow rate</i>	$p_1 = 10 \text{ bar}; p_2 = 6.3 \text{ bar}; \Delta p = 1 \text{ bar}$	$Q_{\text{max}}$ 14600 NI/min
Elemento filtrante <i>Filter element</i>		30 $\mu\text{m}$

Caratteristiche di portata  
*Flow characteristics*

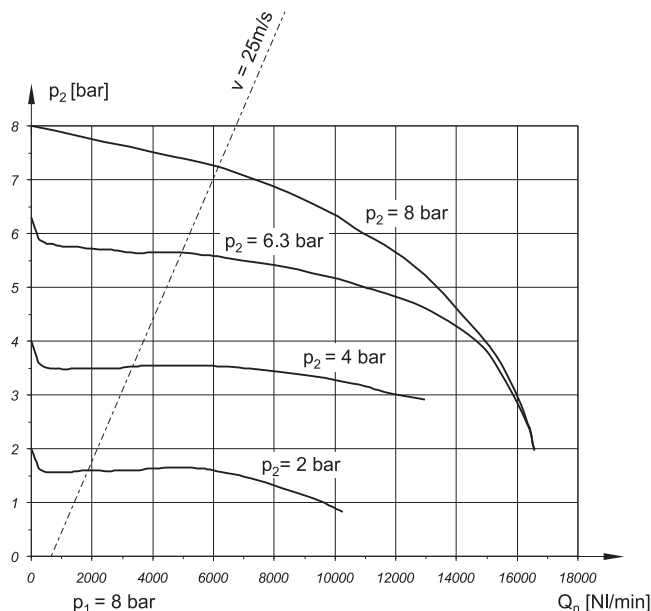

# gruppo trattamento aria FR+L G1"

G1" FR+L air preparation unit



Le staffe di fissaggio, la ghiera e il manometro devono essere acquistati separatamente.  
Mounting brackets, ring and manometer are bought separately.

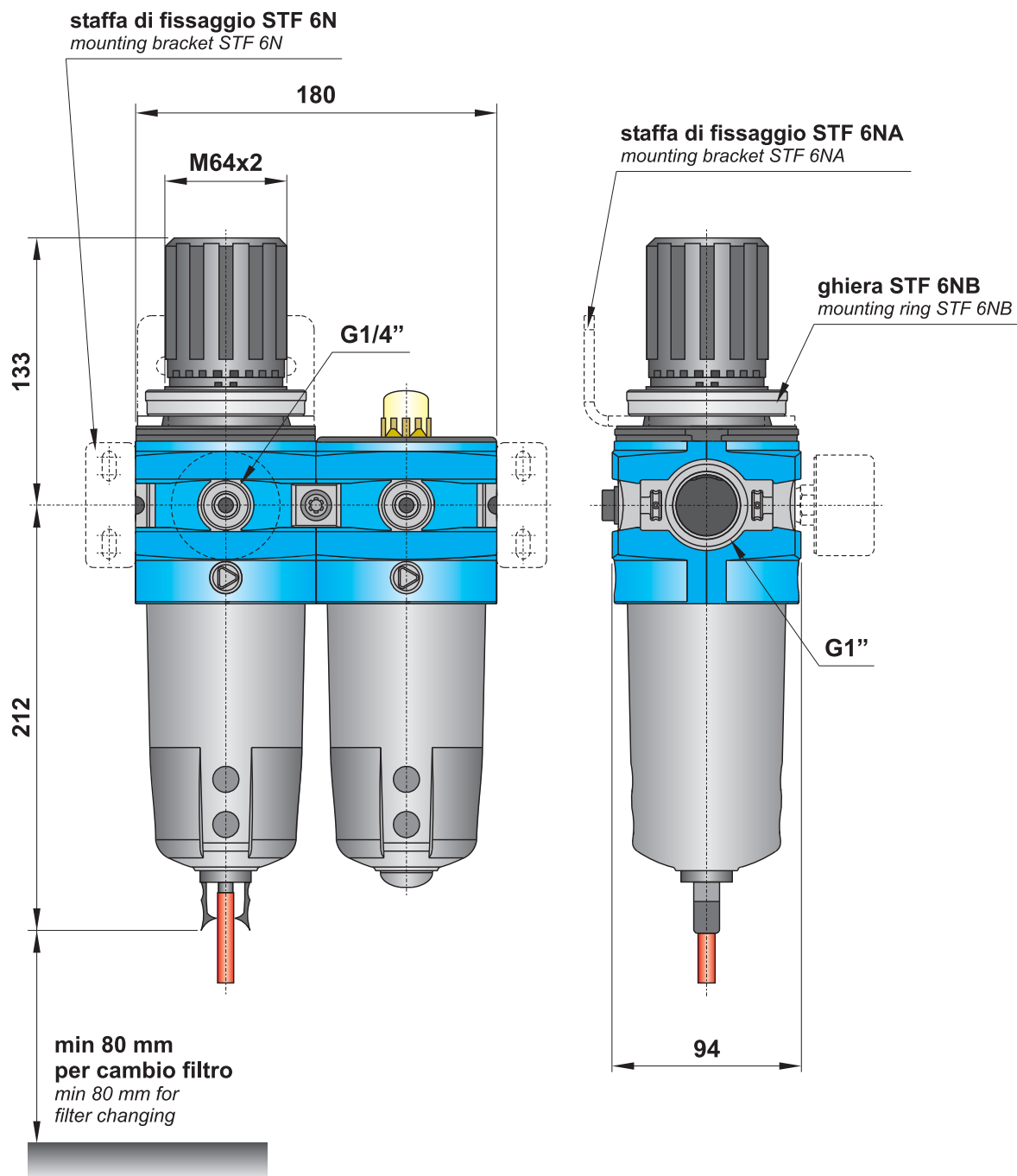
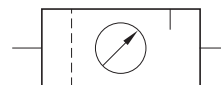

## Materiali

Corpo: alluminio pressofuso

Guarnizioni: NBR

Parti interne: ottone e INOX

Parti esterne: polimeri rinforzati

Tazze: metalliche

## Materials

Body: die-cast aluminium

Seals: NBR

Internal parts: brass and stainless steel

External parts: reinforced polymer

Bowls: metal